

# **JANOME DESKTOP ROBOT**

## **JR2000N Series**

# **Operation Manual**

## **<Setup>**

**“For Qualified Installer ONLY”**

Thank you for purchasing the Janome Robot.

**\*Read this manual thoroughly in order to properly use this robot.**

**Be sure to read “For Your Safety” before you use the robot. It will protect you from possible dangers during operation.**

**\*After having read this manual, keep it in a handy place so that you or the operator can refer to it whenever necessary.**

# **JANOME**

# FOR YOUR SAFETY

## Safety Precautions



The precautions stated in this manual are provided for the customer to make the best use of this product safely, and to provide preventive measures against injury to the customer or damage to property.

• • • • **Be sure to follow the instructions** • • • • •

Various symbols are used in this manual. Please read the following explanations to understand what each symbol stands for.











### **Symbols indicating the Degree of Damage or Danger**

The following symbols indicate the degree of damage or danger which may be incurred if you neglect the safety notes.

	<b>Warnings</b> These "Warnings" indicate the possibility of death or serious injury.
	<b>Cautions</b> These "Cautions" indicate the possibility of accidental injury or damage to property.

### **Symbols indicating the type of Danger and Preventive Measures**

The following symbols indicate the type of safety measure that should be taken.

	Indicates the type of safety measure that should be taken.
	Take care. (General caution)
	Indicates prohibition.
	Never do this. (general prohibition)
	Do not disassemble, modify or repair.
	Do not touch. (contact prohibition)
	Indicates necessity
	Be sure to follow instructions.
	Be sure to unplug power supply from wall outlet.
	Be sure to check grounding.

## FOR YOUR SAFETY

### Warnings



**Be sure to check grounding.**

Improper grounding can cause electric shock or fire.



**Be sure to use within the voltage range indicated on the unit.**

Failure to do so may cause electric shock or fire.



**Plug the power cord into the wall outlet firmly.**

Failure to do so can cause the input to heat up and may result in fire.  
Make sure that the power plug is clean.



**Be sure to unplug the power cord from the wall outlet when you examine or grease the machine.**

Failure to do so may cause electric shock or fire.



**Stop operation and unplug immediately whenever you sense any abnormalities, such as a pungent odor. Immediately contact the dealer from which you purchased the product.**

Continued operation may result in electric shock, fire or malfunction.



**Install the product in a place which can endure it's weight and conditions while running.**

Be sure to leave a space greater than 30cm between the back of the robot (equipped with a cooling fan) and the wall. Installation in an insufficient or unstable place can cause the unit to fall, overturn, breakdown, or overheat.



**Be sure to take protective measures such as installing an area sensor or enclosure to avoid injury.**

Entering the robot's work range during operation could lead to injury.



**Do not attempt to disassemble or modify the machine.**

Disassembly or modification may cause electric shocks, fire or malfunction.

## FOR YOUR SAFETY

### Warnings



**Use the machine indoors where no flammable or corrosive gas is present.**  
**Emission and accumulation of such gasses could lead to fire.**  
IP Protection Rating is "IP30." ("IP40" for CE specification)



Be sure to unplug the power cord from the wall outlet if the robot will remain unused for long periods of time.  
Gathered dust could lead to fire.



**Be sure to use power in the proper voltage range.**  
Failure to do so may result in fire or malfunction.



**Keep the unit and the power cables away from water and oil.**  
Failure to do so may result in electric shock or fire.



**Turn off the unit before inserting and removing cables.**  
Failure to do so may result in electric shock, fire, or malfunction of the unit.  
IP Protection Rating is "IP30." ("IP40" for CE specification)



**Keep the emergency stop switch within reach of an operator while teaching and running the robot.**  
Failure to do so may lead to danger since the robot cannot be stopped immediately and safely.



**Regularly check that the emergency stop switch works properly.**  
**For models with I/O-S circuits, also check that they work properly.**  
Failure to do so may lead to danger since the robot cannot be stopped immediately and safely.

## FOR YOUR SAFETY

### Warnings



**Be sure to check grounding.**

Improper grounding may cause malfunction or defect.



**Use the Desktop Robot in an environment between 0 to 40 degrees centigrade with a humidity of 20 to 95 percent without condensation.**

Failure to do so may result in malfunction.

IP Protection Rating is "IP30." ("IP40" for CE specification)



**Use the machine in an environment where no electric noise is present.**

Failure to do so may result in malfunction or defect.



**Use the machine in an environment where it is not exposed to direct sunlight.** Failure to do so may result in malfunction or defect.



**Be sure to confirm that tools such as the electric screwdriver unit, etc. are properly connected.**

Failure to do so may result in injury or defect.



**Check the mounting screws regularly so that they are always firmly tightened.**

Loose screws may cause injury or defect.



**Be sure to check the wiring to the main unit.**

Improper wiring may cause malfunction or defect.



**Be sure to secure the movable parts of the robot before transportation.**

Failure to do so may result in defect or injury.



**Do not bump or jar the machine while it is being transported or installed.**

This can cause defects.

# PREFACE

The Janome Desktop Robot JR2000N Series is a new low cost, high performance robot. We have succeeded in reducing price while maintaining functionality. Energy and space saving is made possible through the combined use of stepping motors and special micro step driving circuits.

The operation manual consists of the following volumes.

Setup	This volume explains how to set up the robot. <b>You must read this volume before you operate the robot.</b>
Maintenance	This volume explains how to maintain the robot.
Basic Instructions	This volume provides safety precautions, part names, and the basic knowledge necessary to operate the JR Series. <b>You must read this volume before you operate the robot.</b>
Quick Start	This volume explains the actual operation of the JR Series with simple running samples.
Teaching Pendant Operation	This volume explains how to operate the robot via the teaching pendant.
PC Operation	This volume explains how to operate the robot from a computer (JR C-Points.)
Features I	This volume explains point teaching.
Features II	This volume explains commands, variables, and functions.
Features III	This volume explains features such as run mode parameters, sequencer program, etc.
Features IV	This volume explains the customizing features.
External Control I (I/O-SYS)	This volume explains the I/O-SYS control.
External Control II (COM Communication)	This volume explains the COM communication control system.
Compiler	This volume explains how to format C&T data that has been changed into a text file using "JR C-Points."
Camera/Sensor Features	This volume explains the features of robots with a camera and Z-sensor installed.
Specifications	This volume provides comprehensive specifications, including mechanical or electrical requirements.

Please be sure to follow the instructions described in these volumes. Proper use of the robot will ensure continued functionality and high performance.

The contents described in this volume are based on the standard application. Menu items may vary depending on models.



**BE SURE TO MAKE A PROPER GROUNDING WHEN YOU INSTALL THE ROBOT.**



Be sure to save data whenever it is added or modified. **Otherwise, changes will not be saved if the power to the robot is cut off.**

# CONTENTS

---

## Setup

FOR YOUR SAFETY	i
PREFACE	v
CONTENTS	vi
INSTALLATION	1
Installation	1
Teaching Pendant Hanging Ring	4
Cable Connection	5
Switching I/O-SYS and I/O-1 Power Supplies	8
HOW TO BACK UP UNIQUE NUMBER AND INITIAL SETTING DATA	9
HOW TO INSTALL ROBOT SYSTEM SOFTWARE	10
C&T DATA BACKUP	11
CONVERTING DATA FROM JR2000 INTO JR2000N	12

# INSTALLATION

## Installation

Turn the rubber feet around to adjust the height. Be sure to make them stable.

JR2200N Series

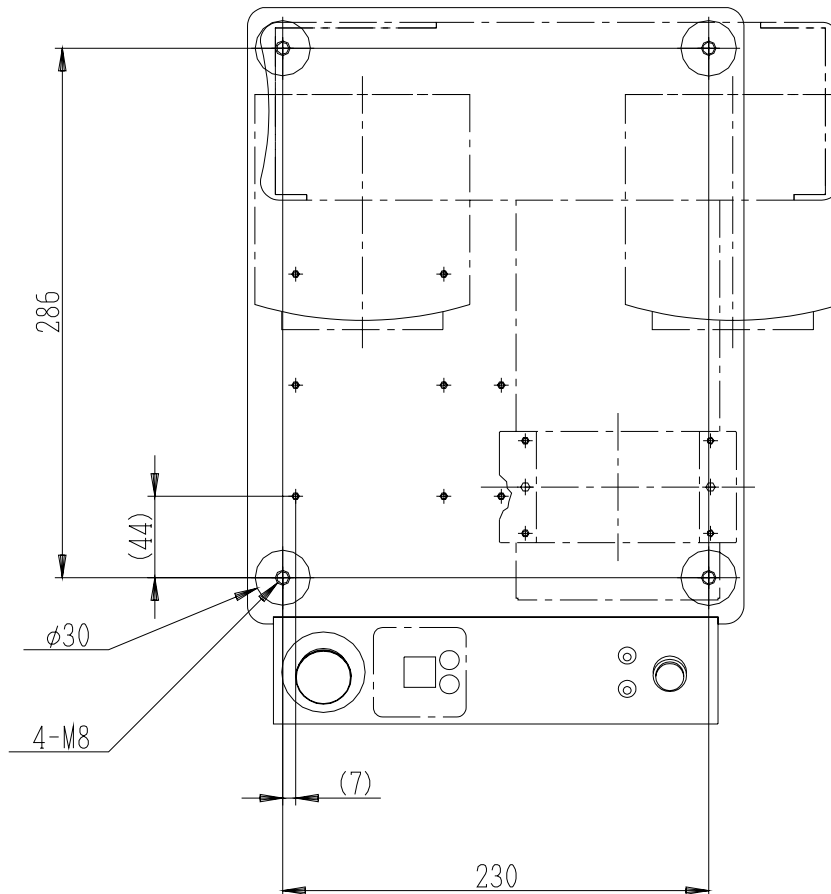

There are four rubber feet (  $\phi 30$ .)

To fix the body, use the four (M8) screws that fasten the rubber feet.

Note that the value inside the brackets is just an example for your reference. It changes depending on how the body is installed.

## JR2300N Series

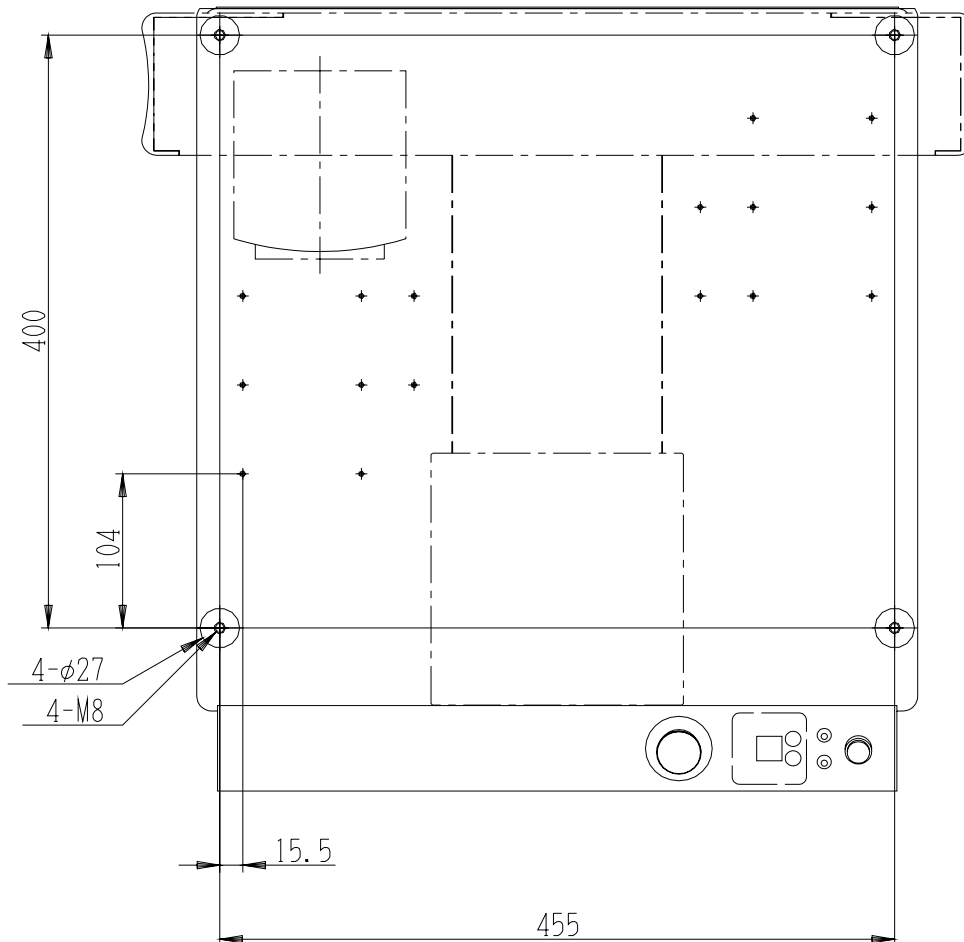

There are four rubber feet (  $\phi 27$ .)

To fix the body, use the four (M8) screws that fasten the rubber feet.

Be sure to use spacers with a height of 20 mm or more to make the body stable.

## JR 2400N Series

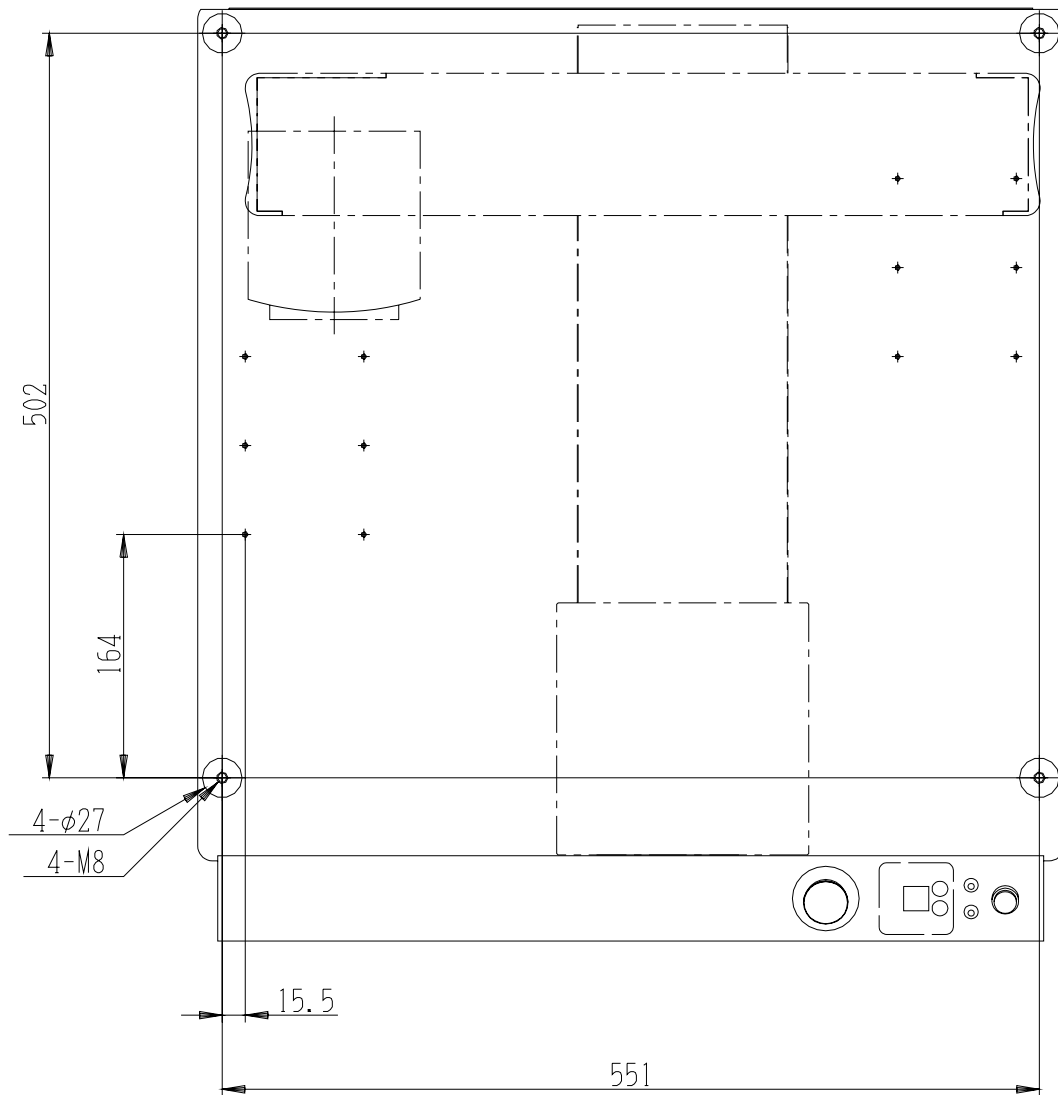

There are four rubber feet (  $\phi 27$ .)

To fix the body, use the four (M8)screws that fasten the rubber feet.

Be sure to use spacers with a height of 20 mm or more to make the body stable.

**Teaching Pendant Hanging Ring**

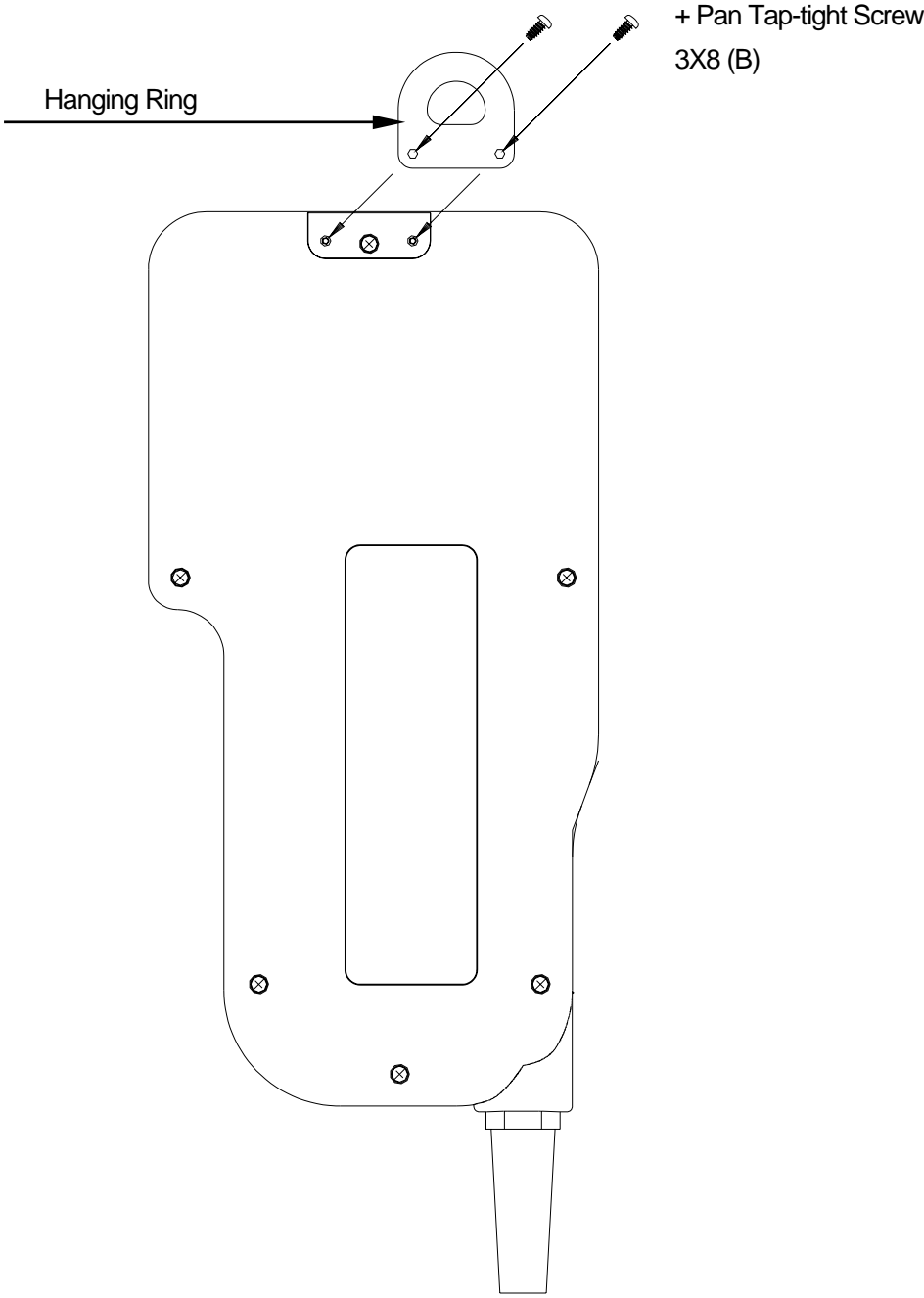

<Back of Teaching Pendant>

## Cable Connection

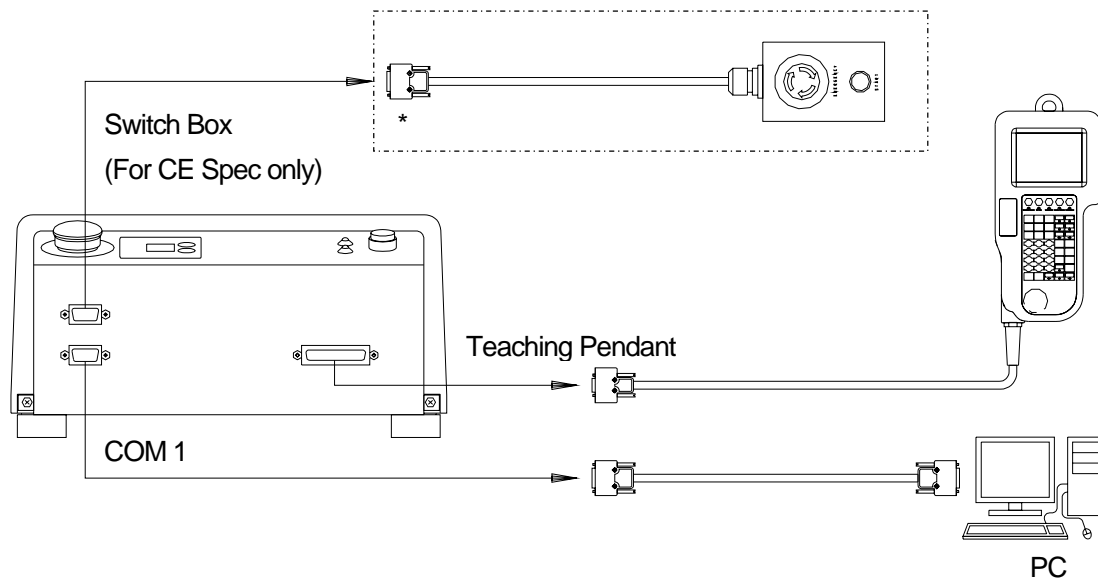

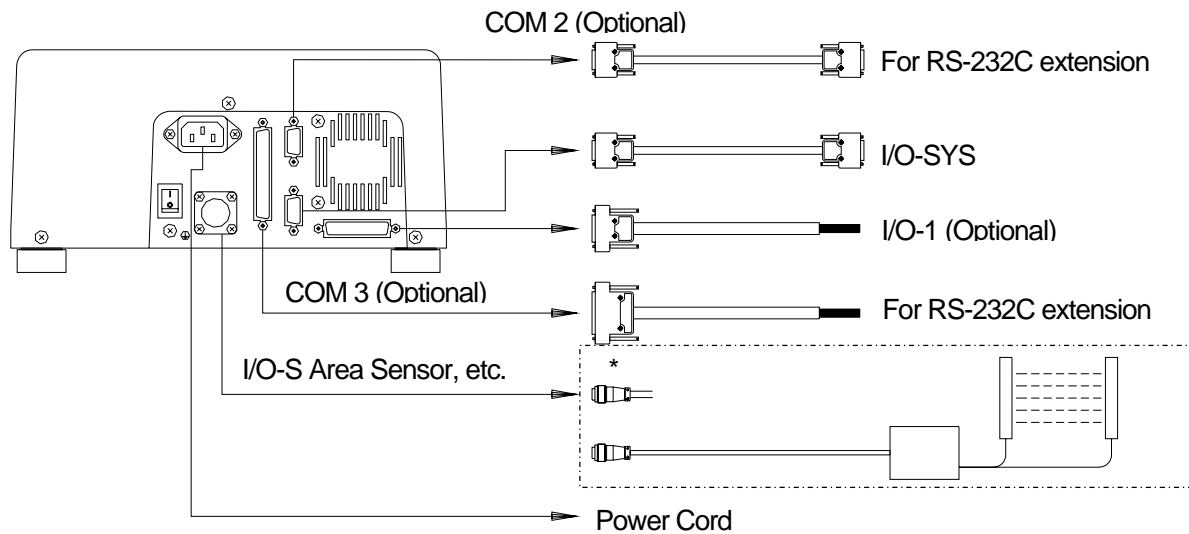

[Back of JR2200N Series]

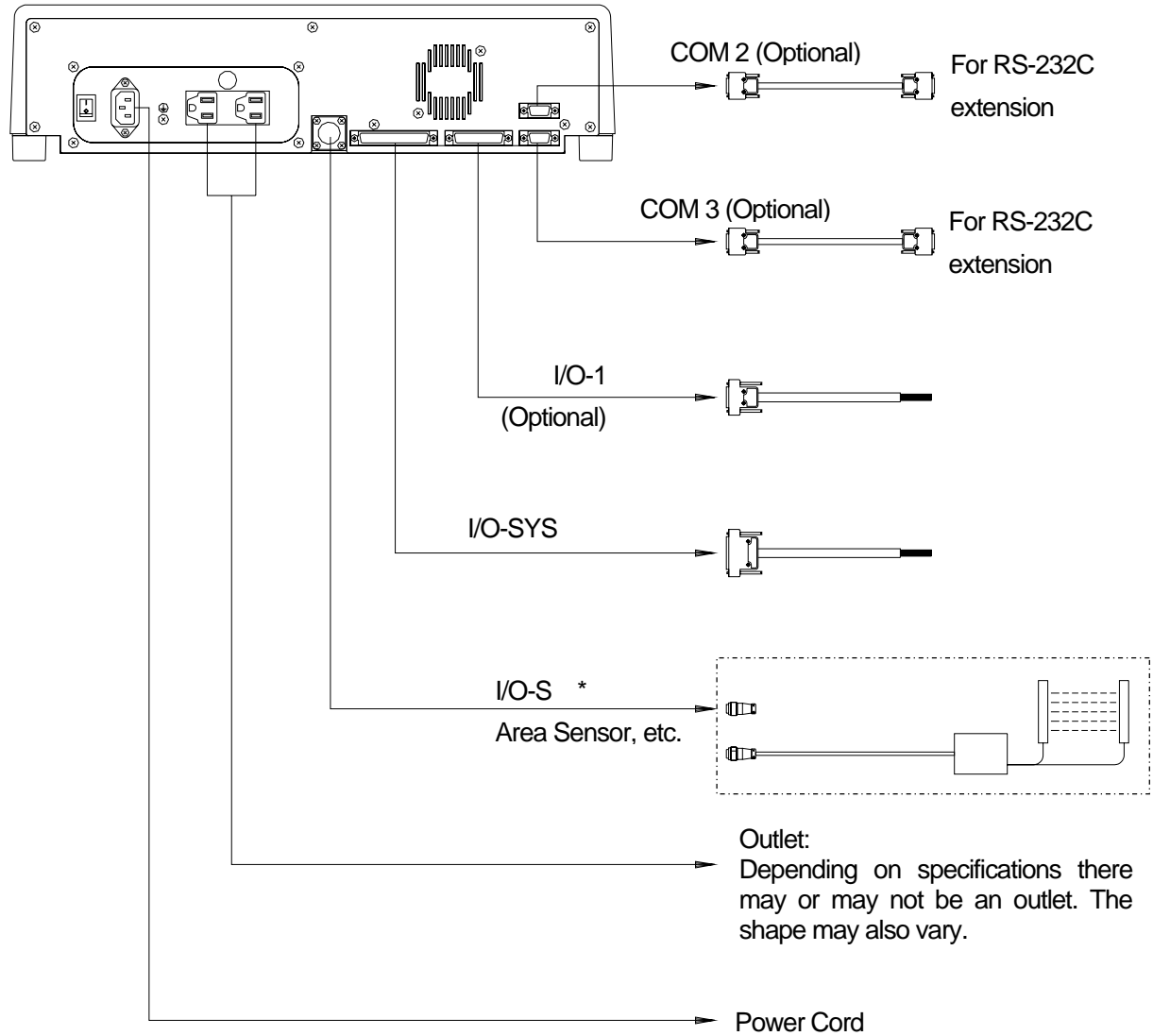

Connect a short connector if you are not using the parts indicated by an asterisk. The robot will not start if nothing is connected. Use the dust cover on unused connectors to prevent any trouble with static or dust. (Except for outlets)

[Back of JR2300N, JR2400N Series]



 Connect a short connector if you are not using the parts indicated by an asterisk. The robot will not start if nothing is connected. Use the dust cover on unused connectors to prevent any trouble with static or dust. (Except for outlets)

Connector Mark		Connecting Cord		Connecting Device		
I/O-SYS		I/O-SYS cable		PLC		
		2m	984937002	Various tools		
		3m	984837105			
		5m	984937208			
		Connector	960537004			
I/O-1 (Optional)		I/O-1 cable		Various tools		
		2m	982544002			
		Connector	961513007			
COM1		RS232C (Straight) D-SUB 9 Pin socket type Not included in package		PC, PLC, etc. Not included in package		
COM2 (Optional)		RS232C (Straight) D-SUB 9 Pin socket type Not included in package		For extension (Camera, etc.)		
COM3 (Optional)		RS232C (Straight) D-SUB 9 Pin socket type Not included in package		For extension (Camera, etc.)		
SWITCH BOX	CE Spec	Coupled with the switch box.		SWITCH BOX	CE Spec	1m 960530007 1.5m 960530018
TEACHING PENDANT		Coupled with the teaching pendant.		Teaching Pendant		963661007 With Emergency Stop 963661100
I/O-S		Short connector	982555006	Area Sensor Safety Guard Switch, etc. Not included in package		
		A connecting cord needs to be re-created using a short connector.				
INLET		Domestic	952801007	Power supply: single phase 90-132 V 50/60 Hz		
		100V Area such as North America, etc. 982559004				
		CE (200v)	980543005	single phase 180-250 V 50/60 Hz		
		200 V area other than CE UK (200 V) 982544006				
OUTLET ( JR2200N series is not equipped with an outlet)				The power supply spec is the same as the power supplied from the INLET. MAX 3A		

## Switching I/O-SYS and I/O-1 Power Supplies

Turn OFF the robot and remove the front cover of the body to change between the following switches.

Switch	Display	IN	EXT
I/O-SYS Power Selection Switch		Internal Power Supply	External Power Supply
I/O-1 Power Selection Switch		Internal Power Supply	External Power Supply

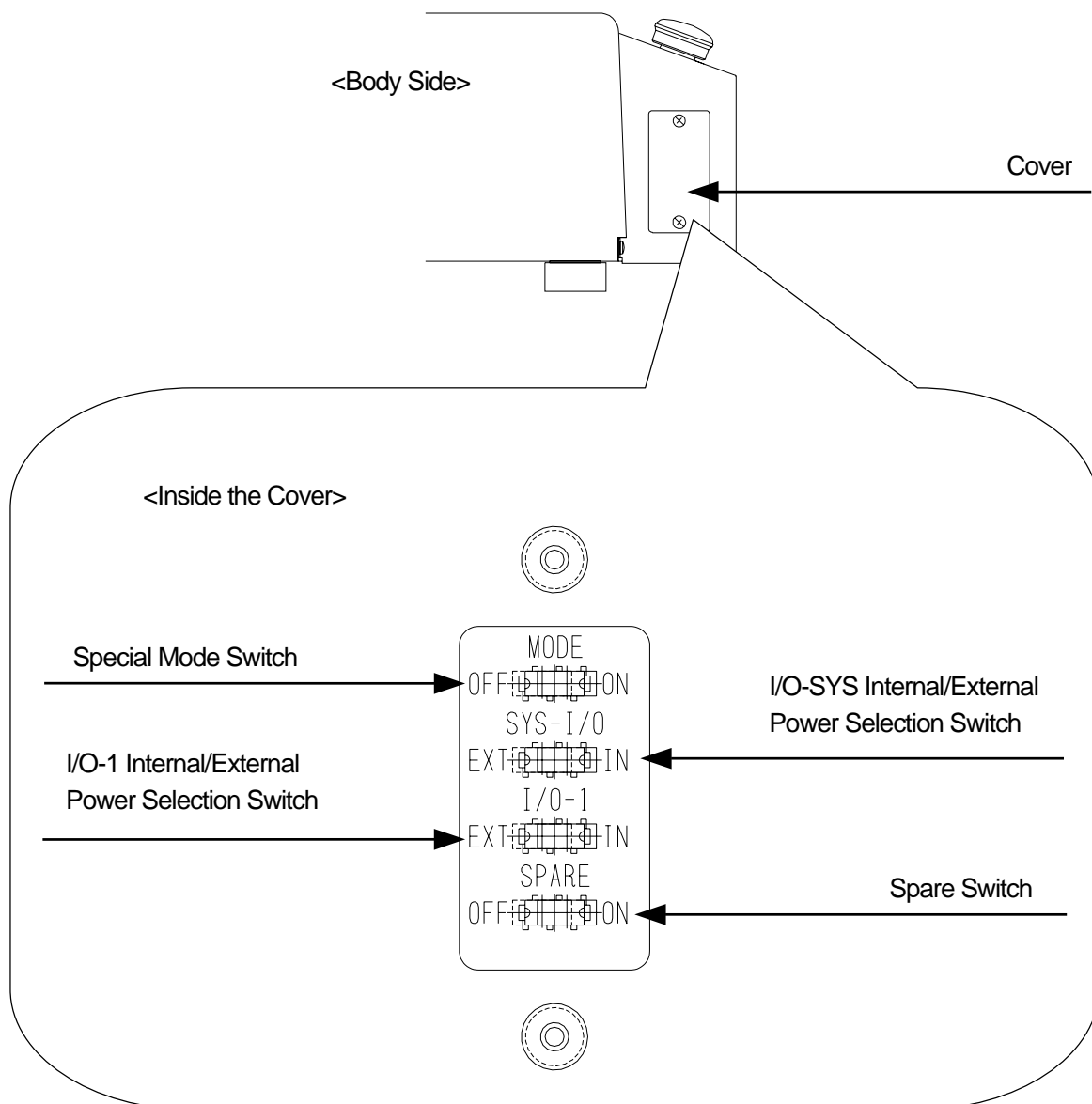

# HOW TO BACK UP UNIQUE NUMBER AND INITIAL SETTING DATA

Each robot has a unique number and its own initial setting data.

Be sure to back up this data since it may be necessary when replacing internal boards due to malfunction.



Be sure to back up the unique number and initial setting data of the robot.  
It may be necessary when replacing internal boards.

## <Preparation>

Check that the robot is properly connected to your PC, turn the robot and the PC ON and copy "PSKBKUPE.EXE" from the Operation Manual CD-ROM to the local disk.

1. Start up "PSKBKUPE.EXE" from the local disk. The dialog box to the right will appear.

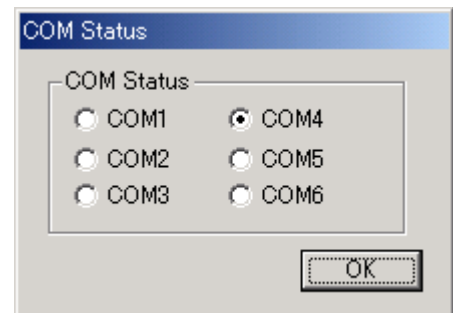

2. Select the COM port used to connect the PC to the robot and click [OK.]

3. Click [Download] to start downloading the unique number and initial setting data of the robot.

If you want to select another COM port, select [COM Status] from the pull-down menu [COM.]

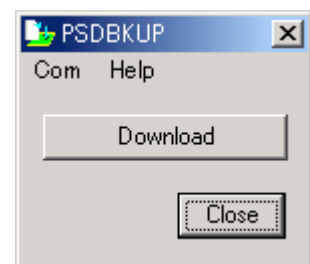

4. After downloading is complete, save it as a new file. (It is saved with the extension ".JPB".) Click [Close] to exit "PSKBKUPE.EXE."

- **Do not execute [Send C&T Data] from the pull-down menu [COM Status.]**

# HOW TO INSTALL ROBOT SYSTEM SOFTWARE

---

This robot is controlled by built-in “Robot system software.” To upgrade the robot system software, follow the instructions below. (For this operation, the robot must be connected to a PC.)

“Robot system software” is included in the Operation Manual CD-ROM with the file name, **JRN\_XAC\_XXX.jsy**. (“X” differs according to applications. “XXX” indicates the version number.)

1. Turn OFF the robot, remove the cover on the left side body and then turn the **special mode switch** ON.
2. Turn ON the robot again, copy the “JSYLOADE” software included in Operation Manual CD-ROM to the local disk on the PC and start it up.
3. Select the communication port status of your PC which is connected to the robot and then click [OK.]
4. Select [Open] on the dialog box and specify the robot system software to be downloaded. Then click the  button.

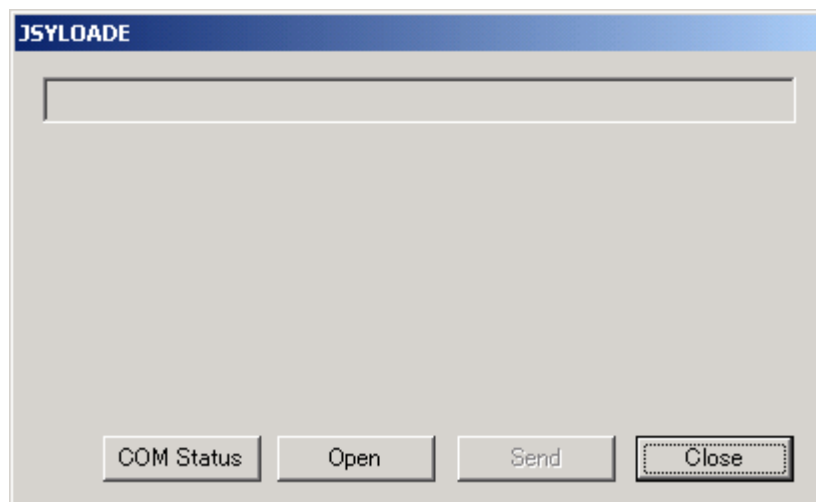

5. After data sending is complete, turn the robot OFF, turn the special mode switch OFF and then reattach the cover.
- If you are using “JR C-Points”, the robot system software can also be upgraded by selecting [Send Robot System Software] from the [Robot] pull-down menu.

# C&T DATA BACKUP

Back up data in case of accident.

To create backup data, start up the program “JR C-Points Limited Edition” included in the Operation Manual CD-ROM. Retrieve data from the robot and save the retrieved data in a file.

The teaching data in combination with the customizing data is sent and received between the robot and PC as a unit of data. This unit of data is called “C&T data.” You cannot send or receive one particular program only.

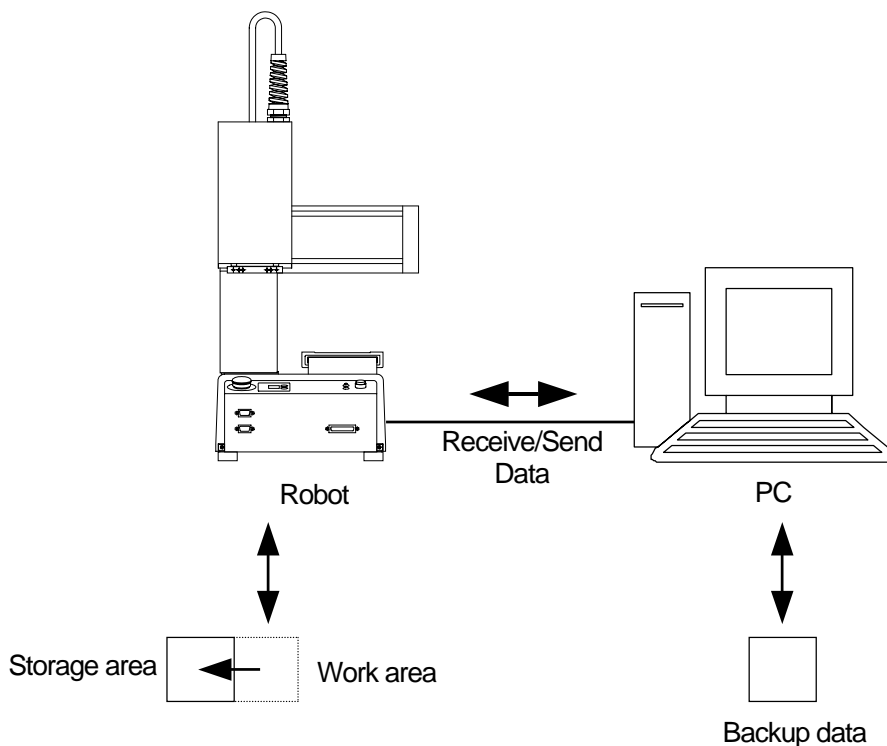

The robot has a data storage area and a work area. When you start up the robot, the C&T data in the storage area will be copied to the work area. The copied data is used for running and teaching. The data in the work area will be deleted when the power to the robot is turned OFF.

When retrieving data from the robot, it comes from the work area. After sending data from the PC to the robot, the sent data will be saved in the storage area automatically.

- If you are using “JR C-Points”, the robot system software can also be upgraded by selecting [Receive C&T Data] from the [Robot] pull-down menu.

# CONVERTING DATA FROM JR2000 INTO JR2000N

If you are using JR2000 teaching data as JR2000N C&T data, it is necessary to convert the data. To convert data, follow these 3 steps.

- 1) Using “JR-Points”, load data onto the PC from the JR2000.
- 2) Using “JR C-Points”\*, open the data sent in 1).
- 3) Using “JR C-Points”\*, send the data from your PC to the JR2000N.

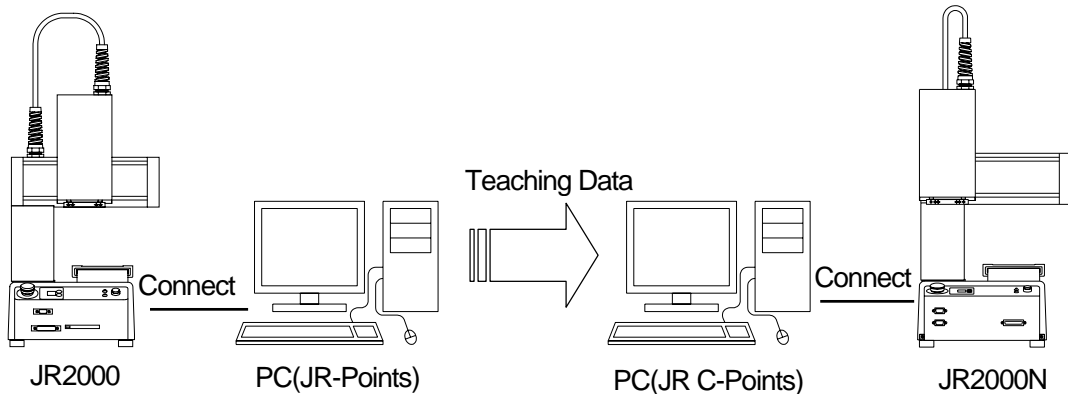

\* As well as “JR C-Points”, “JR C-Points Limited Edition (included in Operation Manual CD-ROM)” can also be used to convert data.

- You can connect one PC to both the JR2000 series and the JR2000N series robots together. It is also possible to connect the PC only to the JR2000 series robot to receive teaching data, disconnect the JR2000 robot and then connect the JR2000N series robot to send the teaching data.  
(To convert data using one PC, both “JR-Points” and “JR C-Points” have to be installed on the PC.)



Be sure to turn the power to the robot and PC OFF before connecting or disconnecting cables.

Follow the steps below to convert teaching data.

(For PCs with “JR-Points” and “JR C-Points” installed, connected to the JR2000 series and JR2000N series robots.)

1. Turn the power to the robot and PC ON. In Run mode, the robot has to be in stand-by to run. In other modes, it has to be in a base state.

2. Start up “JR-Points” on the PC and set the port status to the COM port connected to the JR2000 series robot.

**PC** [Robot] → [COM Status]

3. Transfer teaching data from the JR2000 series robot.

**PC** [Robot] → [Receive Data]

4. When data transfer is completed, the data is opened in “JR-Points.” Name the data and save it.

**PC** [File] → [Save As]

5. Exit “JR-Points” and start up “JR C-Points.”

6. Set the port status to the COM port connected to the JR2000N series robot.

**PC** [Robot] → [COM Status]

7. Open the data file from the JR2000 series robot.

**PC** [File] → [Open]

8. Send the data to the JR2000N series robot. Note that when data is sent from the PC to the robot, any data stored in the robot is deleted.

**PC** [Robot] → [Send Data]

- For operation environment of “JR-Points”, refer to the operation manual for JR-Points.
- For operation environment of “JR C-Points” and “JR C-Points Limited Edition”, refer to PC Operation, JR2000N series Operation Manual.

# **JANOME Sewing Machine Co., Ltd.**

**Industrial Automation Systems Division**

**Zip Code: 193-0941**

**1463 Hazama-cho, Hachioji-shi, Tokyo, Japan**

**Tel: +81-426-61-6301**

**Fax: +81-426-61-6302**

The specifications of the robot or the contents of this manual may be modified without prior notice to improve its quality.

No part of this manual may be reproduced in any form, including photocopying, reprinting, or translation to another language, without the prior written consent of JANOME.

©2004, JANOME Sewing Machine Co., Ltd., All rights reserved.

963807111 as of 02/2005

02/2005